

ECART



BRUNO MOINARD

GENÈVE BRIDGE

Varnished solid oak & fabric.

CM	IN
H. 76	H. 30
L. 68	W. 26.75
P. 58	D. 22.75

BRUNO MOINARD

For Bruno Moinard, drawing and painting are foundational acts that have shaped his journey since an early age. Growing up in Dieppe, where he found inspiration in the local landscapes, he moved to Paris to study at the École Nationale Supérieure des Arts Appliqués, earning his degree there. His passion for interior architecture drove him to fully commit to the discipline.

In 1979, Moinard joined the newly established Ecart International, founded by Andrée Putman—a pivotal experience in his career. The 1980s brought a surge of creativity for the agency, which took on iconic projects such as apartments and boutiques for designers like Thierry Mugler, Karl Lagerfeld, Azzedine Alaïa, and Chloé. Other significant projects included the Morgans Hotel in New York, the office of French Culture Minister Jack Lang, the interior design of the Concorde, the Sheraton Hotel at Roissy, and the reissue of Mariano Fortuny's lamp.

In 1995, Bruno Moinard left Ecart and established his own firm, 4BI. His expertise and connections quickly led to prestigious projects, including the renovation of Christie's in New York for François Pinault and the transformation of Château Latour in Pauillac. In 2002, he secured a major contract with Cartier, overseeing the design of their boutiques worldwide. Moinard also worked on numerous private residences, hotels, and restaurants, showcasing his distinctive style both in France and abroad.

In 2020, his studio evolved into Moinard Bétaille, marking the beginning of a successful partnership with Claire Bétaille. She shares his passion for art history and brings the same hands-on, pencil-in-hand approach to her work. Together, they represent the essence of the French art of living, drawing inspiration from materials and light, and approaching each project with deep sensitivity and meticulous attention to detail.

In 2014, Bruno Moinard launched Bruno Moinard Éditions, offering a new vision with a collection of furniture, lighting, and accessories. He

continues to design for other publishers and, in a full-circle moment, has developed several pieces for Ecart International, reconnecting with the roots of his career.



ECART

UPHOLSTERY



Christian Sand



Margareta Grey

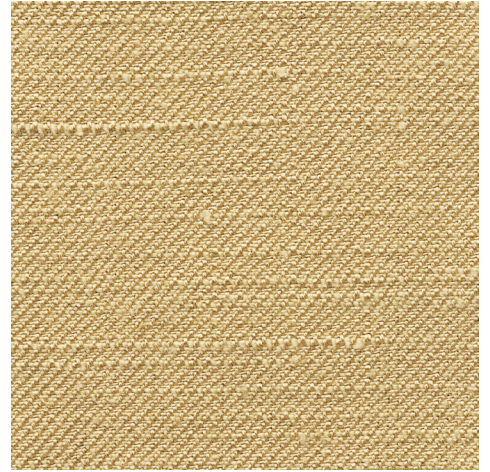

Emilio Sand



Black leather



Dark chocolate leather



Cognac leather

WOOD

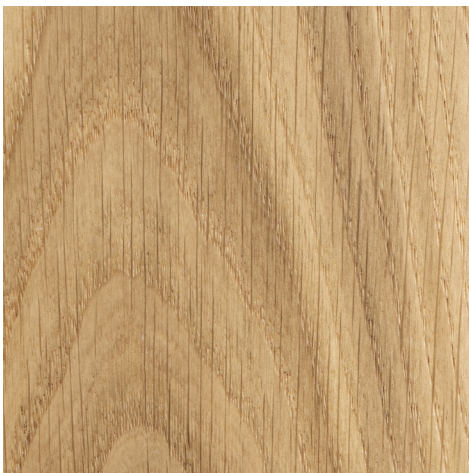

Smooth natural oak with matte varnish



Smooth brown oak with matte varnish



Smooth black oak with matte varnish

ECART

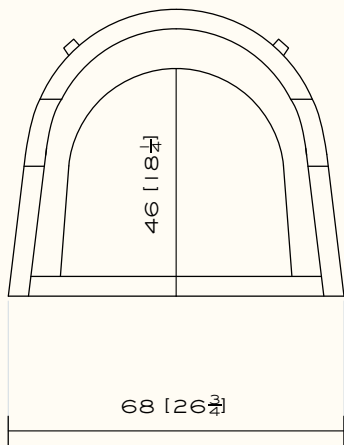
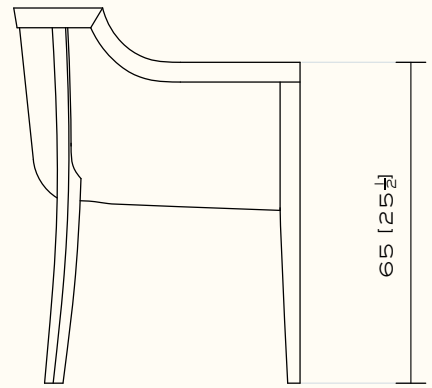
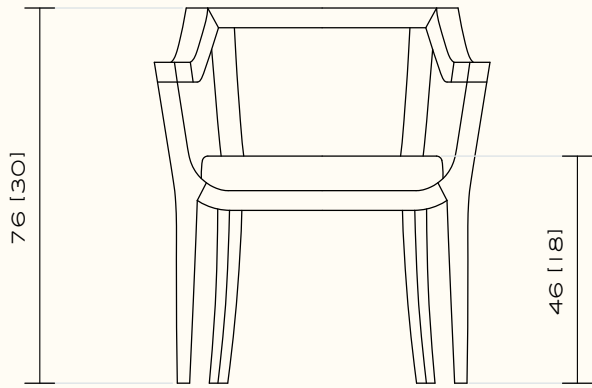

BRUNO MOINARD

GENÈVE BRIDGE

Upholstery: Fabric (COM: 3 m) or leather
Frame: Natural, brown or black solid oak.
Finish: Smooth with matte varnish.

ECART