

ECART



EILEEN GRAY
(1879 - 1976)

TRANSAT
(c. 1927)

Lacquered beech frame & cowhide.

CM	IN
H. 79	H. 31
L. 49	W. 19.5
P. 108	D. 42.25

EILEEN GRAY (1879 - 1976)

Determined and independent, the young Irish aristocrat born in 1878 arrived in London in 1900 to study drawing. She explored the Victoria and Albert Museum, where she first discovered the history of furniture and Chinese and Japanese lacquer screens. The slow and intricate process of lacquer work fascinated her, and she began learning the technique with D. Charles, a restorer. In 1902, she moved to Paris with two friends and attended the Académie Julian, known for its free and innovative atmosphere. Very liberated in her personal life, she had several relationships but never married. She immersed herself in museums, galleries, and salons, and attended her first Salon d'Automne in 1903.

In 1907, Eileen rented an apartment at 21 Rue Bonaparte in Paris, which she purchased three years later and where she lived for 70 years. She also rented a workshop on Rue Guénégaud for her master, Seizo Sugawara, a young Japanese lacquer artist. Together, they delved deeper into the art of lacquer work, and Eileen surpassed Jean Dunand (1877-1942) in her experimental techniques. Her screens bore poetic names, such as The Milky Way and Destiny, the latter of which was purchased by renowned couturier Jacques Doucet in 1914. After the war, Doucet commissioned her to create pieces for his «modern studio,» including The Lotus Table, The Chariot Table, and The Bilboquet Table.

Around 1907, textiles became another passion for Eileen Gray. With her childhood friend Evelyn Wyld, she traveled to Morocco to learn weaving techniques. They established a workshop at 17 Rue Visconti, managed by Evelyn. Eileen's textile designs were boldly abstract.

Although she contributed to the Art Deco movement, the apartment she designed for Mme Mathieu-Levy on Rue de Lota (1920-1924) was a subtle blend of simplicity, rigor, and sophistication. The space featured brick partitions, a lacquered wooden «canoe» bed, and chairs adorned with serpents.

To promote her work, Eileen opened the Jean Desert gallery in 1921 on Rue du Faubourg Saint-Honoré, in collaboration with architect Jean Badovici (1893-1956). The gallery offered «furniture, lacquer, screens, and carpets,» as well as a «decoration and apartment installation» service. Among her clients were Raymond Poincaré, Maurice Thorez, Martin du Gard, Henri Pacon, Charles Moreux, and Henri Laurens. Her reputation grew, and the Chicago Tribune described her gallery in 1922 as offering «a visit to the unseen.»

In 1923, she made a strong impression at the Salon des Artistes Décorateurs with her Boudoir Bedroom for Monte-Carlo. Complimented by Pierre Chareau and Francis Jourdain, this marked a turning point in her career. Inspired by artists from the Vhutemas and the De Stijl movement, she began producing serially manufactured furniture, following in the footsteps of Francis Jourdain and the «Ateliers Modernes» (1912) and department store art workshops. Encouraged by Jean Badovici, Eileen ventured into architecture. Her first house project in 1923 was inspired by Adolf Loos's The Little House. Her masterpiece is the E1027 House in Roquebrune-Cap-Martin

(1926-1927), built on stilts and featuring highly functional interiors, where she experimented with new materials and techniques. Her paradoxical humor was reflected in her furniture designs, such as the Transat chair, the «satellite» mirror, the Bibendum armchair, and the one-armrest seat.

From 1926 to 1929, she designed tubular furniture prototypes sold in her gallery, described as «camping style.» These pieces followed a systematic logic: they folded, rotated, interlocked, and retracted. In 1929, she became a founding member of the Union des Artistes Modernes, separated from Jean Badovici, and closed her gallery and lacquer workshop in 1930.

Returning to the south of France, she built the house Tempe a Pailla (1934) near Castellar on ancient foundations. Each room was conceived as a self-contained space, integrating both interior and exterior environments. During World War II, Eileen continued to draw, paint, and reflect. In 1954, she built her final house near Saint-Tropez, characterized by great simplicity. She continued working on projects until her death on October 31, 1976.



ECART



EILEEN GRAY
(1879 - 1976)

TRANSAT
(c. 1927)

ECART



EILEEN GRAY
(1879 - 1976)

TRANSAT
(c. 1927)

ECART



EILEEN GRAY
(1879 - 1976)

TRANSAT
(c. 1927)

ECART

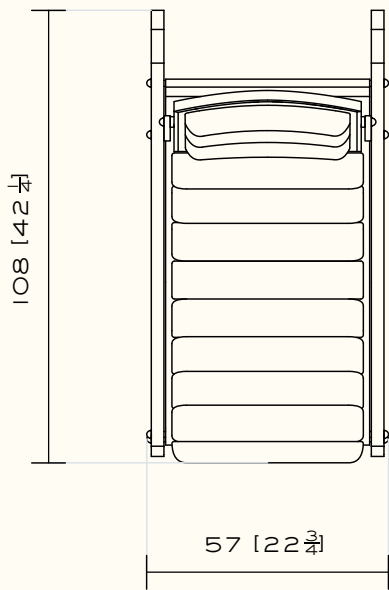
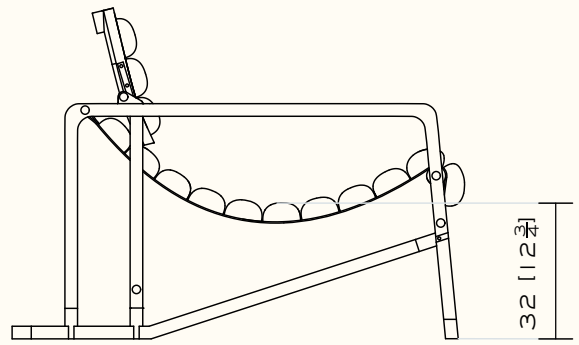
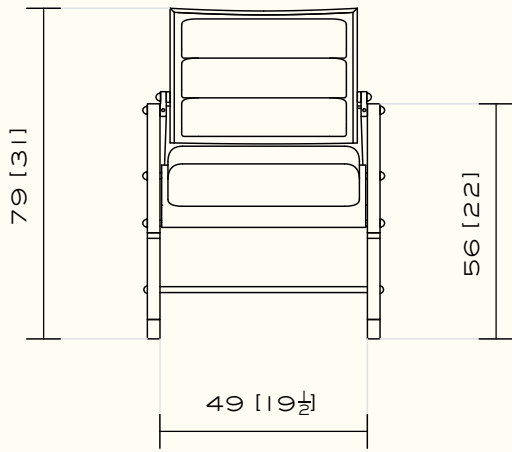

EILEEN GRAY
(1879 - 1976)

TRANSAT
(c. 1927)

Upholstery: Leather or hide.
Frame: Natural beech or black lacquered beech.
Adjustable back cushion.

ECART