

ECART



MARIANO FORTUNY
(1871 - 1949)

PROJECTOR
(c. 1907)

Black lacquered steel, chrome plated brass & fabric.

CM	IN	CM	IN
H. 168	H. 66	H. 238	H. 93.75
L. 89	W. 35	L. 89	W. 35
P. 82	D. 32	P. 82	D. 32

MARIANO FORTUNY (1871 - 1949)

Mariano Fortuny y Madrazo was born in Granada in 1871 into an artistic family. His father, a renowned painter with an international reputation, had a deep love for history and built an impressive collection of objects and fabrics. During a trip to Rome in 1874, he tragically died of malaria at the age of 36. The family then moved to Paris, where Mariano began learning painting, copying the masters in museums, and studying the treasures his father had collected. Due to health concerns, his mother decided to leave Paris for Venice in 1889. For 18-year-old Mariano, Venice's timeless atmosphere strengthened his belief that studying the past could teach him more than the shifting trends of contemporary artistic groups and doctrines.

His mother, Dona Cecilia, hosted prestigious guests in their Martinengo Palace, such as Isaac Albéniz, Martín Rico, José Benlliure, Walter Sickert, Henri de Régnier, and Paul Morand. In 1893, Mariano, along with his mother and sister, discovered Wagner's universe in Bayreuth—a revelation. The composer's philosophy profoundly influenced him, and he embraced the idea of a total art, Gesamtkunstwerk.

Fortuny was a fusion of technician, artist, and craftsman. Through painting, he learned to use color and seek harmony. His printmaking work was highly expressive, as he enjoyed layering elements, much like he would later do with his fabrics, playing with light and transparency. He also held great admiration for photography, using it for his pictorial studies.

His ambitions and projects were vast. In 1900, he settled with his wife Henriette in the Pesaro-Orfei Palace. In his self-imposed solitude, in the independence of his Venetian studio, Fortuny, an insatiable creator, explored all fields: painting, engraving, sculpture, photography, lighting techniques, and invention—he held numerous patents. He was also a stage director, furniture designer, architect, and creator of fabrics and clothing. He crafted his own lamps and made functional furniture for his studio and home. His wife managed the workshops. Fortuny began fabric printing in 1907 and established a factory on the Giudecca in 1915. He opened a fashion store on Boulevard Haussmann in Paris in 1919. The products he sold, such as fabrics and garments, maintained consistent forms. He perfected the same pleated silk technique for 40 years, finding fulfillment in this pursuit without ever tiring of it.

After World War I, he became recognized as a decorator. A passionate lover of textiles, Fortuny transformed the homes of the elite, designing

interiors for Consuelo Vanderbilt, Marie-Laure de Noailles, Dina Galli, and the gaming room of the new Excelsior Hotel on the Lido.

He was fascinated by the progressive society of his time, studying the mechanics of how things worked and engaging in inventions. On April 21, 1901, he patented his system of indirect stage lighting in Paris, followed by a project for a mobile dome, which was realized with the AEG company in 1906 and installed in several theaters. He continued creating scenographies, sets, and dome installations well into the 1930s. Mariano Fortuny passed away in Venice in 1949.



ECART



MARIANO FORTUNY
(1871 - 1949)

PROJECTOR
(c. 1907)

ECART



MARIANO FORTUNY
(1871 - 1949)

PROJECTOR
(c. 1907)

ECART



MARIANO FORTUNY
(1871 - 1949)

PROJECTOR
(c. 1907)

ECART



MARIANO FORTUNY
(1871 - 1949)

PROJECTOR
(c. 1907)

ECART

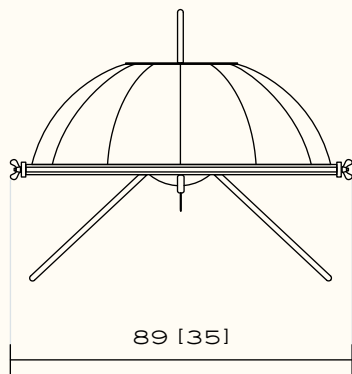
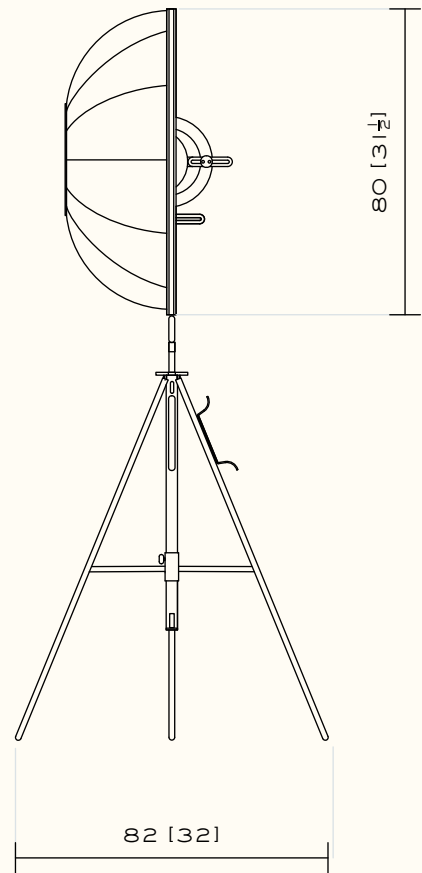
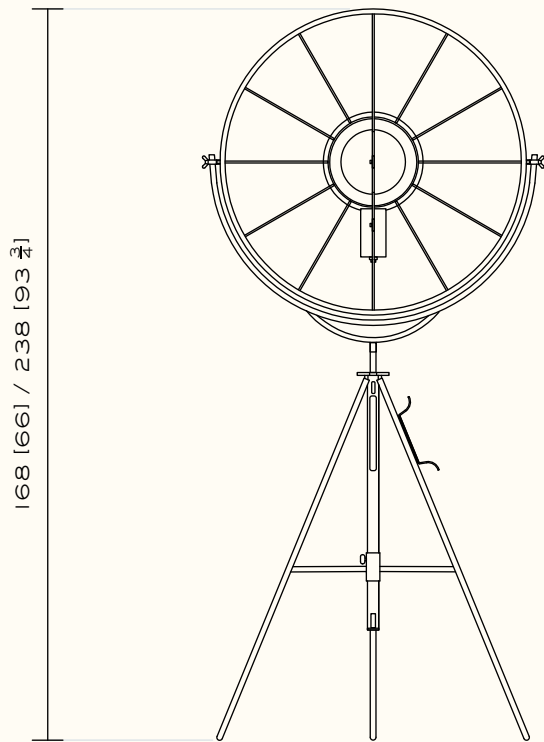

MARIANO FORTUNY
(1871 - 1949)

PROJECTOR
(c. 1907)

Lampshade adjustable in height.
300W E40 max.

ECART