

ECART



OLIVIA PUTMAN

REST ARMCHAIR

Varnished solid oak & fabric.

CM	IN
H. 80	H. 31.5
L. 94	W. 37
P. 93	D. 36.75

## OLIVIA PUTMAN

Born in 1964, Olivia was raised in an environment shaped by her mother Andrée Putman, a designer and interior architect, and her father, an art publisher and collector. She developed a keen sensitivity to the objects around her and a deep passion for art, with a particular interest in Chinese landscapes, the Renaissance, and modern art. She studied art history at the Sorbonne in Paris, graduating in 1987. She chose to become an artistic agent and, in 1989, co-founded Usines Éphémères, an association aimed at transforming disused spaces into artists' studios, blending her appreciation for both architecture and art.

She curated exhibitions with Land Art artists. Her connections with figures like Christian Louboutin and Vincent Darré, as well as Jean-Michel Basquiat, inspired her. She admired Basquiat's freedom and watched him create, but their friendship was cut short when he passed away in August 1988. Drawn to landscape design, she worked as a landscape architect for two years with Louis Benech.

In 2007, Olivia Putman took over the direction of the studio, which became «Studio Putman.» Her mother, at 83 years old, passed the company on to her. Olivia followed in her mother's footsteps while establishing her own identity, designing objects and furniture to enhance people's daily lives. Andrée Putman proudly mentioned having worked for Prisunic in 1968, and Olivia herself excelled in various domains: hotel renovations, furniture and lighting design, as well as the scenography of concerts and exhibitions. She created designs for brands such as Les Forges de Laguiole, two collections for Deshoulières, outdoor furniture for Fermob, rugs for Toulemonde-Bochart, fabrics for Pierre Frey, and a collection for Drucker.

In January 2011, she was appointed artistic director of the Lalique brand. This beautiful story of mother-to-daughter transmission continues today, where Olivia perpetuates her mother's method and expertise to invent harmonious, thoughtful, and welcoming spaces. Today, Olivia is dedicated to preserving and advancing her mother's legacy and work.



# ECART

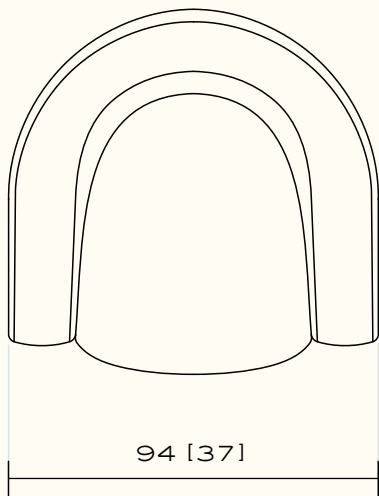
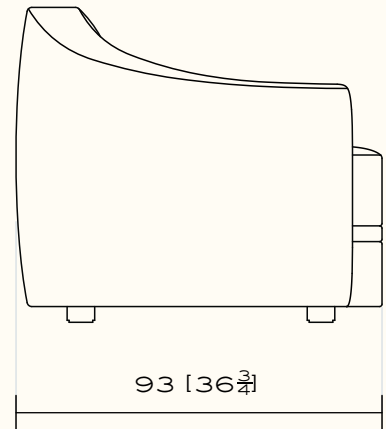
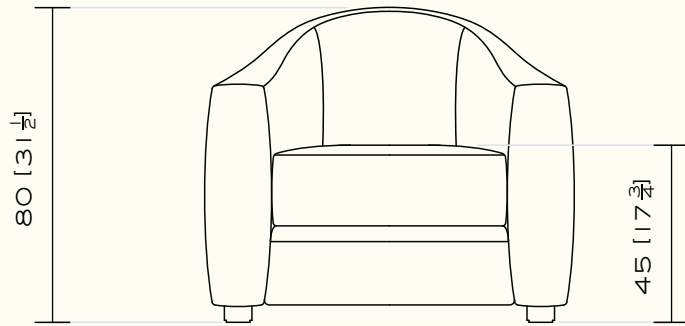

OLIVIA PUTMAN

REST ARMCHAIR

Upholstery: Fabric or leather.  
Feet: Natural, brown or black oak.  
Removable cushion.

ECART